

15. Slide the outer side brackets onto the pole, inserting a ring in between the two brackets, fix bracket to the wall Fig. 12

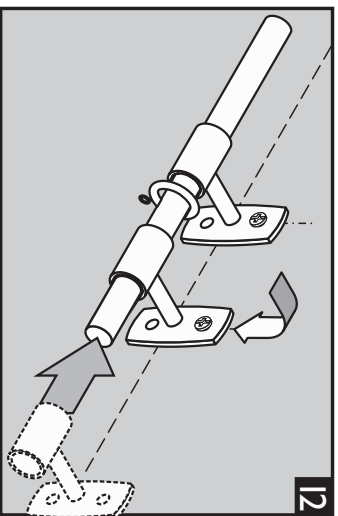

16. Tighten both screws on both brackets securely, Fig. 13.

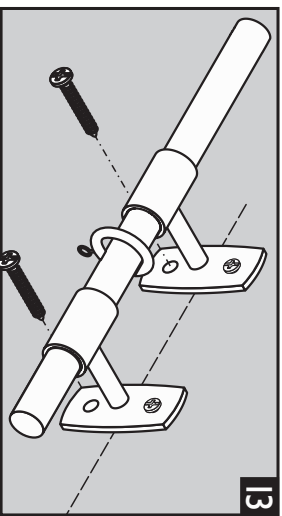

17. Slide the remaining ring onto the pole as shown in Fig. 14.

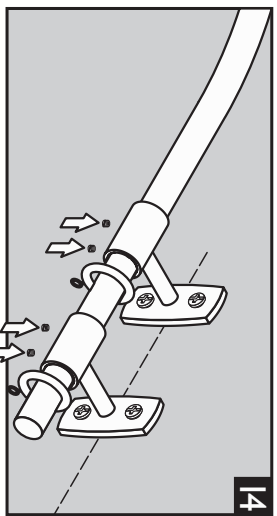

18. Using a small flat screwdriver, fit and tighten the locking screws on the side brackets and tighten the locking screws on the centre bracket, Figs. 14 & 15.

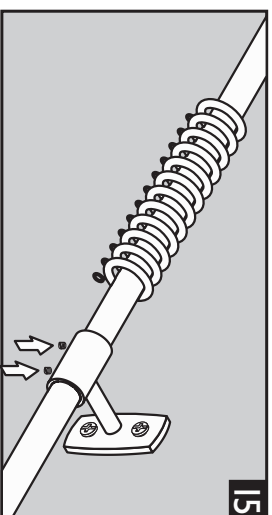

19. Push the finials onto the ends of the pole and tighten the locking screw, Fig. 16.

20. The pole is now ready to accept curtains by slipping curtain hooks through the eyelets on the rings.

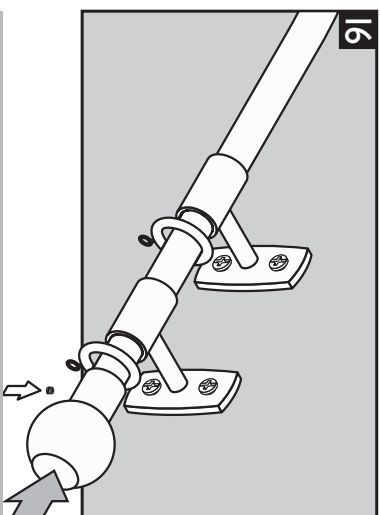

Safety

- Only use a step ladder or stable chair to reach fixing height.
- Do not over reach. Always move the stepladder or chair, so that you are in a safe working position.
- Do not hold or lean on the pole to support your weight.
- Use two people for the installation of longer poles.
- Take care when using power tools, use of a Residual Current Device (RCD) is recommended.
- Always wear eye protection when drilling.
- Beware of hidden pipe runs and cables.



Bay Curtain Pole

(to fit maximum bay widths 2.14m and depth 0.9m)

Fitting Instructions

Before you fit your curtain pole please read these instructions carefully. Check the contents to ensure that all the components are present.

Contents List	Qty
A Pole Lengths	2
B Brackets	5
C Rings	34
D Fixing Pack - masonry wall	1
E Finials	2
F Splice	1

Should any component be missing, please call the Customer Care Department on 0800 515493.

Tools required: Steel Tape measure, Soft Pencil, Posi-Drive Screwdriver, Spirit level, Drill and 6mm Masonry Drill bits, Hacksaw.

Installation & Assembly

1. Carefully remove packaging to avoid any damage to the poles and fittings.
2. To determine the length of pole required it is important to measure the Bay width and Bay depth, Fig. 1. This will confirm that you have sufficient pole length to fit your bay. This bay pole will fit bay widths up to 2.14m and depths of 0.9m.

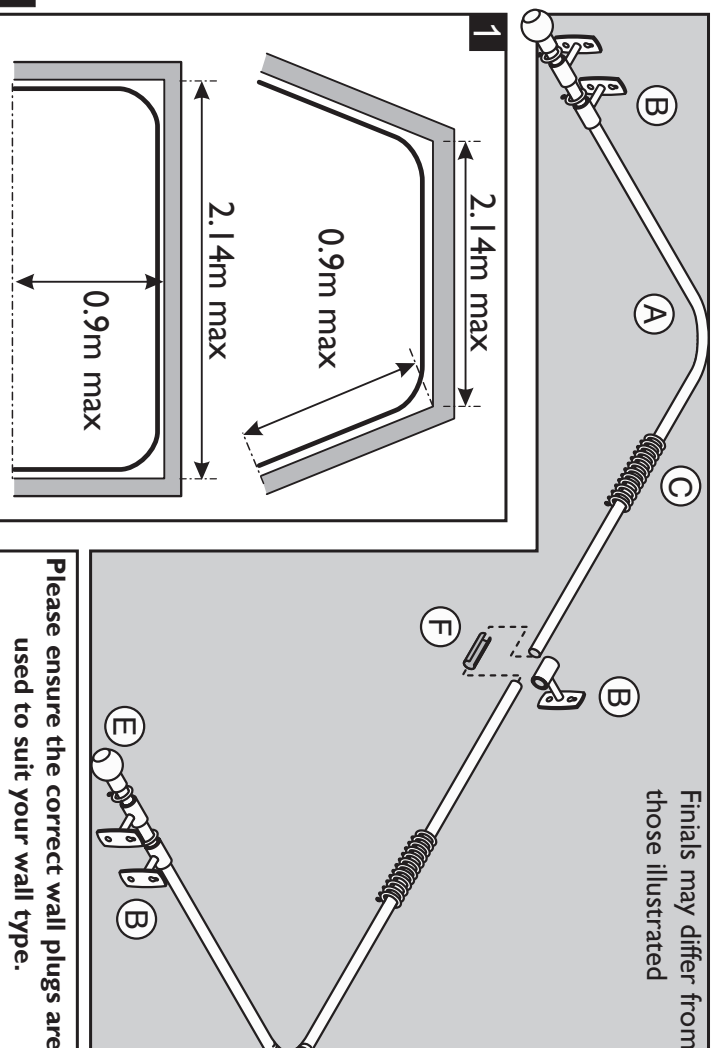

Finials may differ from those illustrated

Please ensure the correct wall plugs are used to suit your wall type.



Integra Products Ltd
High Point, Sandy Hill Business Park,
Sandy Way, Armington, Tamworth,
Staffordshire B77 4DU

• tel: +44 (0)1543 267100 • fax: +44 (0)1543 267105
• email: cus.care@integra-products.co.uk
• web: www.integra-products.co.uk

L5000A/ISS2

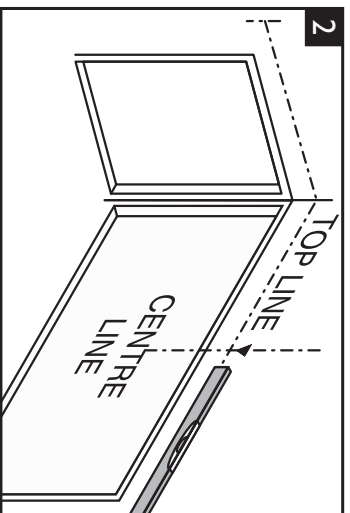

2. Use a spirit level to mark the line of the brackets, approximately 100mm (4") above the window and mark the centre point of the window, Fig. 2.

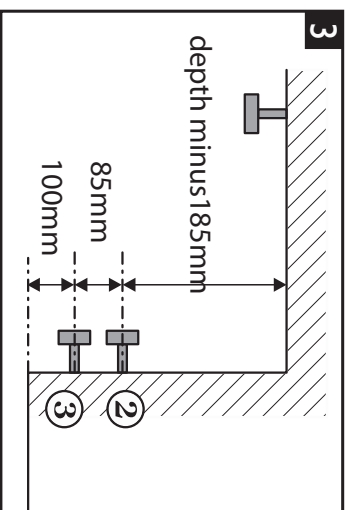

3. Use a spirit level to mark the line of the brackets, approximately 100mm (4") above the window and mark the centre point of the window, Fig. 2.

4. Mark on the wall approximately 100mm (4") in from the edge of the window to situate the outer of the two side brackets. Measure and mark a further 85mm (2.5") to situate the inner of the side brackets, Fig. 3.

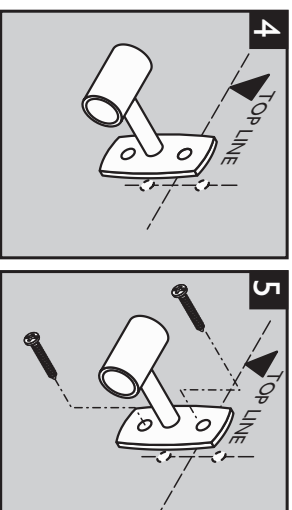

4

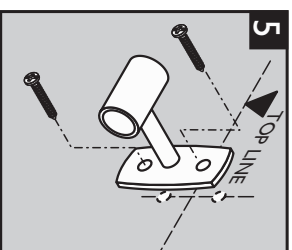

5

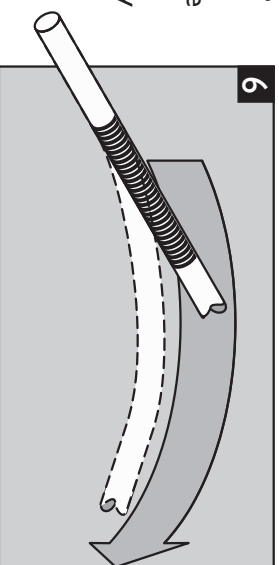

6

5. Position the centre wall bracket at the mid point along the top line, then mark and drill the holes using a 6mm masonry drill bit (use the appropriate drill for alternative fixings).

6. Carefully bend each pole to suit the corners of the bay window as shown in Fig. 6, ensuring that the cut slots are on the inside of the bend.

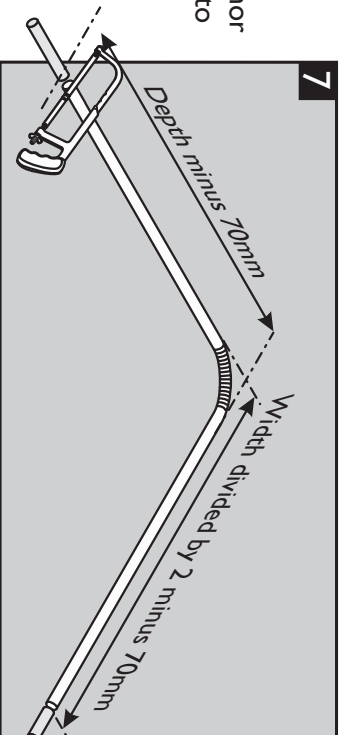

7

Note: You can make minor adjustments to the bend to achieve a perfect fit. However, this should be limited to avoid any detrimental distortion of the bend.

8. To shorten the poles to suit the window dimensions, use a hacksaw and ensure you remove equal amounts from left and right hand poles, Fig. 7. Deduct 70mm to allow for the projection of the brackets.

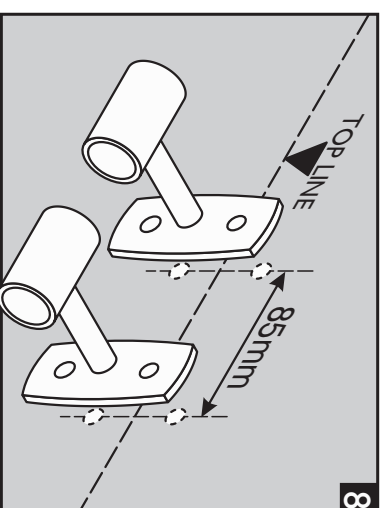

8

9. Position the inner side bracket at the position marked out earlier, in Fig. 3, mark and drill the holes, above and below the top line as shown in Fig. 8, using a 6mm drill bit (or alternative if required).

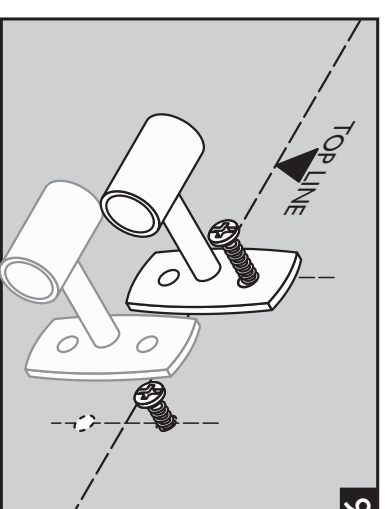

9

10. Repeat this for the outer side bracket 85mm from the inner bracket, drill the holes using a 6mm drill bit (or alternative if required).

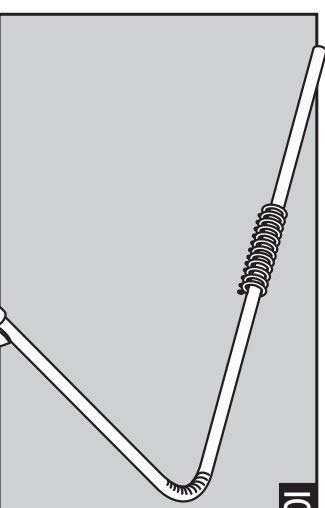

10

11. Repeat step 9 and 10 for the other side of the bay.

12. Slide on 1 ring for every 10cm of pole, leaving two rings for the outer brackets and final, Fig. 10. Slide the inner side bracket onto the pole.

13. Insert the pole into the centre bracket as shown in Fig. 11. Raise the pole (two persons may be required for this operation), screw the inner bracket onto the wall, Fig. 11.

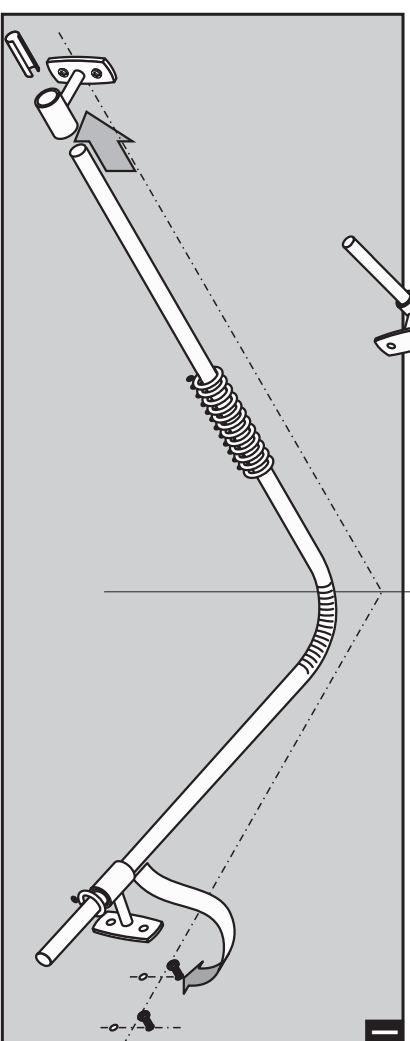

11

14. Insert the joining splice into the pole and repeat the procedure with the other side of the bay.